

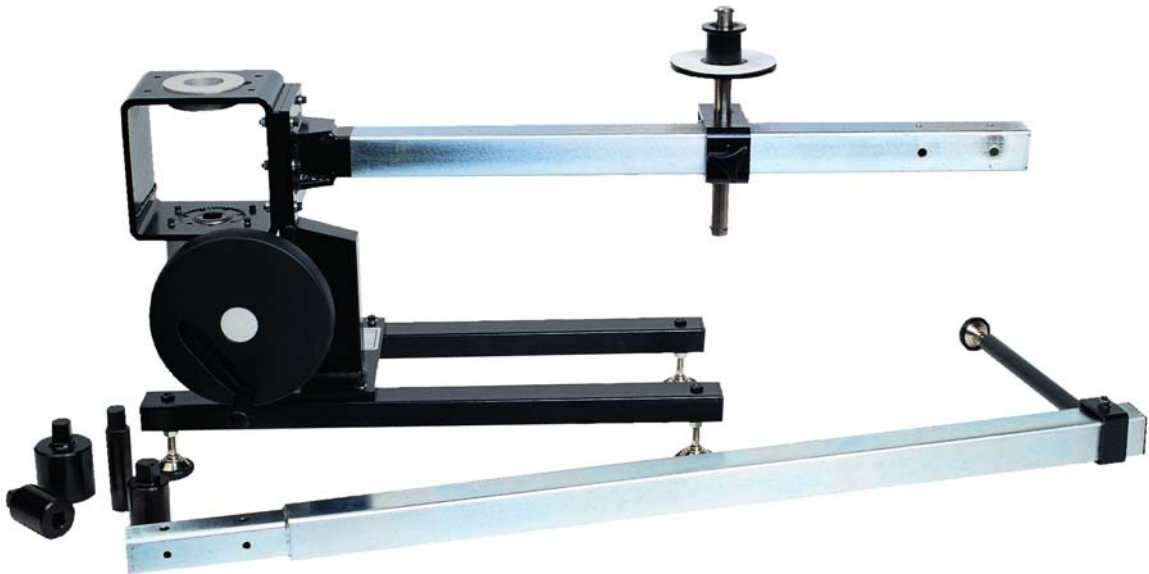

# ISO 3000 TORQUE WRENCH LOADER

**OPERATORS HANDBOOK (PART NO. 34378)**  
ISSUE 1

Original Instructions



NORBAR TORQUE TOOLS LTD, Beaumont Road, Banbury, Oxfordshire, OX16 1XJ, UNITED KINGDOM

Tel : + 44 (0) 1295 270333, Fax : + 44 (0) 1295 753643

[www.norbar.com](http://www.norbar.com)

[enquiry@norbar.com](mailto:enquiry@norbar.com)



## CONTENTS

	<u>PAGE</u>
Introduction	2
Features and Functions	3
Installation	4
Operating Instructions	5
Maintenance	6
Specification	6

## INTRODUCTION

The Norbar ISO 3000 Torque Wrench Loader is designed to test torque wrenches up to a maximum capacity of 3000 N.m or 2200 lbf.ft.

To measure the applied torque a torque transducer coupled to an appropriate measurement instrument are required.

### MODELS COVERED BY THIS HANDBOOK :- \_\_\_\_\_

This handbook covers 20502 only.

### SAFETY WARNINGS :- \_\_\_\_\_



- The ISO 3000 is heavy. Take care when installing.
- Ensure the operating area is capable of taking the weight of the ISO 3000.
- Trapping hazard - Keep hand and loose clothing away from the torque wrench during use.
- To avoid damage to the torque wrench under test do not exceed the wrench set torque value.
- To avoid damage to the transducer do not exceed the maximum capacity.
- Never exceed the maximum torque capacity of the ISO 3000 (3000 N.m / 2200 lbf.ft).
- Do not operate without a torque measurement system connected and working.
- The ISO 3000 is designed for testing torque tools, do not use for other purposes.

### PARTS INCLUDED :- \_\_\_\_\_

Parts included	Part Number	Quantity
ISO 3000	20505	1
Adaptor 1 1/2" male to 1" female	21214	1
Adaptor 1 1/2" male to 3/4" female	86034.4	1
Adaptor 1" male to 1 1/2" female	20502.49	1
Adaptor 1" male to 1" female	20502.48	1
Adaptor 1" male to 3/4" female	20502.47	1
Adaptor 1" male to 1/2" female	20502.46	1
Adaptor 1/2" to 3/8"	25429	1
Adaptor 1/2" male to 3/8" female	29614	1
Adaptor 1/2" male to 1/4" female	29610	1
Collar (small)	20502.51	1
Collar (medium)	20502.52	1
Collar (Large)	20502.53	1
Reaction post	-	1
Extension arm (with leg, dowels & 5mm hex key)	-	1
Hand wheel	-	1
Operators Handbook	34378	1

### ACCESSORIES :- \_\_\_\_\_

Accessories available	Part Number
Norbar torque measurement system.	Consult Norbar
Reaction Plate for small torque wrenches. (Wrench length 100mm to 180mm).	20588

## FEATURES AND FUNCTIONS

- Allows torque wrenches to be calibrated or tested in accordance with ISO 6789:2003, BS EN 26789:2003 and American military standard GGG-W-686.
- Also available with 1500 N.m capacity, see ISO 1500 N.m (Part number 60118).
- For part identification see drawing below:

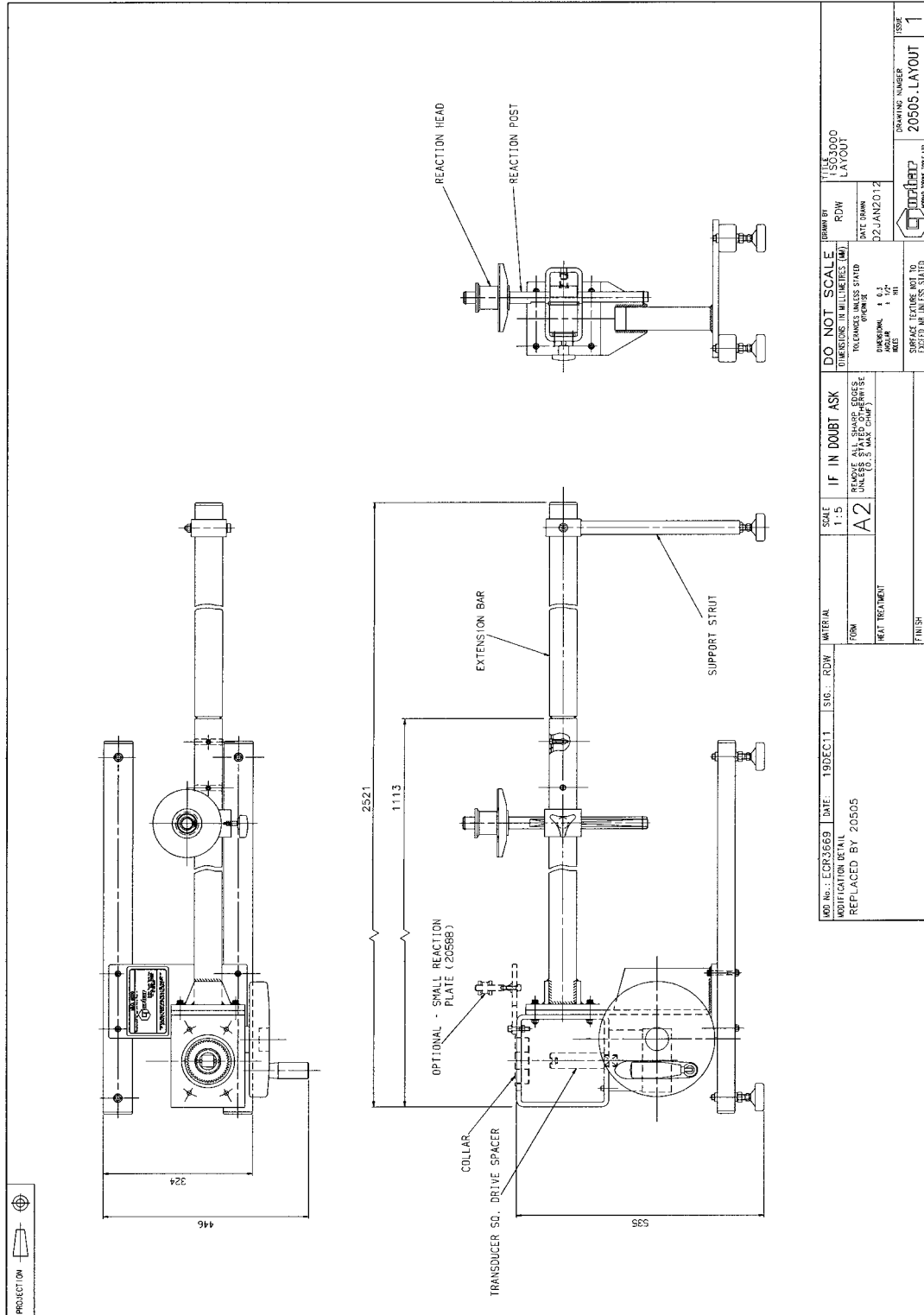

## INSTALLATION

**NOTE:** If the equipment is used in a manner not specified by the manufacturer, the protection provided by the equipment may be impaired

**ITEMS REQUIRED:** \_\_\_\_\_

Norbar torque transducer to suit capacity of test with suitable torque display instrument.

**LOCATION:** \_\_\_\_\_

Ensure location can cope with weight of loader.  
Locate ISO 3000 on a level surface at a comfortable working height.

**TOOL REACTION POST:** \_\_\_\_\_

Slide "Tool reaction post" on to the reaction bar.

**REACTION PLATE FOR SMALL TORQUE WRENCHES (option):** \_\_\_\_\_

To use small torque wrenches a smaller reaction plate may be required.

Fix using M8 socket cap screws provided with reaction plate.  
Tighten to 20N.m.

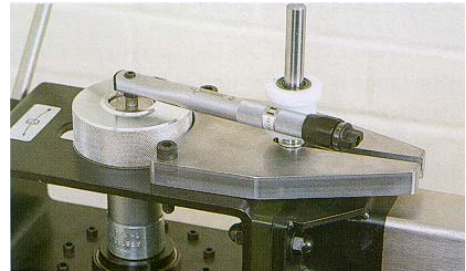

**EXTENSION ARM :-** \_\_\_\_\_

For long torque wrenches fit extension arm as follows:

1. Fit the small square of the extension arm into the existing arm.
2. Insert the two locating dowels through the horizontal holes.  
Keep thread vertical.
3. Fit securing pins from the top of the arm into vertical thread.  
Tighten with 5mm hex key (included) as shown in picture.
4. Attach the support strut at the end of the extension arm.



**REACTION POST :-** \_\_\_\_\_

Slide reaction post onto ISO 3000 reaction arm.

**TORQUE MEASUREMENT:** \_\_\_\_\_

Select the lowest capacity torque transducer to cover the wrench to be tested.

Mount the male square of the transducer into the female square of the gear box, use adaptors to suit.

Place collar over the transducer.

Connect a transducer lead from the transducer to the instrument.

Ensure the instrument functions correctly. (If in doubt see operators handbook).

## OPERATING INSTRUCTIONS

### LOCATING A TORQUE WRENCH :- \_\_\_\_\_

Select the correct adaptor to place the torque wrench drive into the transducer.

Set the reaction post position on the reaction arm so it is in the middle of the torque wrench handle.

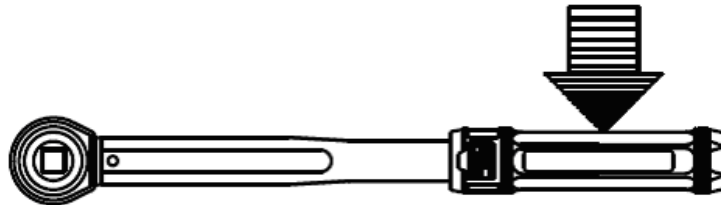

Set the reaction post height to ensure the wrench handle is parallel to the reaction arm.

If the Torque Wrench is too small for the reaction arm use reaction plate option (Part 20588).  
If the Torque Wrench is too big for the reaction arm fit extension arm supplied - See installation.

The large gear box ratio makes movement in the output drive difficult to detect.  
Use the 'A' and 'B' arrows on the hand wheel and gearbox output as an indication.

For clock-wise calibration 'A' indicates direction to apply force & 'B' indicates direction to release force.

**TIP.** In the case of a ratchet wrench, with push through square drives, it is important to ensure the square is operating on the correct side of the ratchet.

## MAINTENANCE

The ISO 2700 is engineered for a long maintenance free life. Under normal operation maintenance is not required.

When cleaned do not use abrasive or solvent based cleaners.

For maintenance and recalibration of the instrument and transducer refer to their handbooks.

## SPECIFICATION

MAXIMUM OUTPUT TORQUE	3000 N.m / 2200 Lbf.ft
TORQUE WRENCH LENGTH	With small reaction plate option = 125mm to 210 mm Standard reaction arm = 220mm to 1100mm With extension arm = up to 2200mm
DIRECTION OF TORQUE APPLICATION	Clockwise and Anticlockwise
SQUARE DRIVE SIZES	1/4", 3/8", 1/2", 3/4", 1" & 1 1/2"
GEAR RATIO	1250:1
CALIBRATION DIRECTION	Clockwise and Anti-Clockwise
OPERATING TEMPERATURE RANGE	0 °C to +50 °C
STORAGE TEMPERATURE RANGE	-20 °C to +70 °C
MAXIMUM OPERATING HUMIDITY	80% Relative Humidity @30°C
DIMENSIONS (without extension bar)	535 mm high x 1123 mm wide x 446 mm deep
DIMENSIONS (with extension bar)	535 mm high x 2533 mm wide x 446 mm deep (height without reaction post fitted)
WEIGHT	55 Kg

*NOTE : If equipment is used in a manner not specified by the manufacturer, the protection provided by the equipment could be impaired.*